

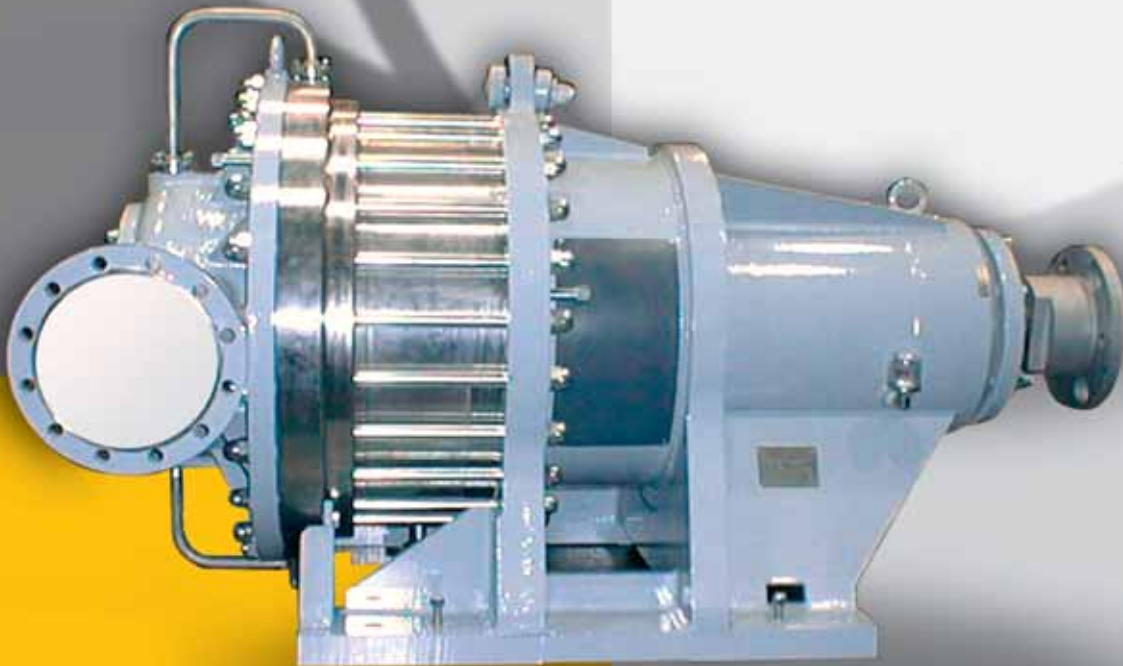

# Garro

Since 1947 design and manufacture  
Liquid Ring Compression Systems  
for the handling of:

- WET GASES without dehydrating plants
- GASES WITH FRACTIONS of solid elements (powder and particles)
- CONDENSABLE, TOXIC, CORROSIVE and EXPLOSIVE GASES



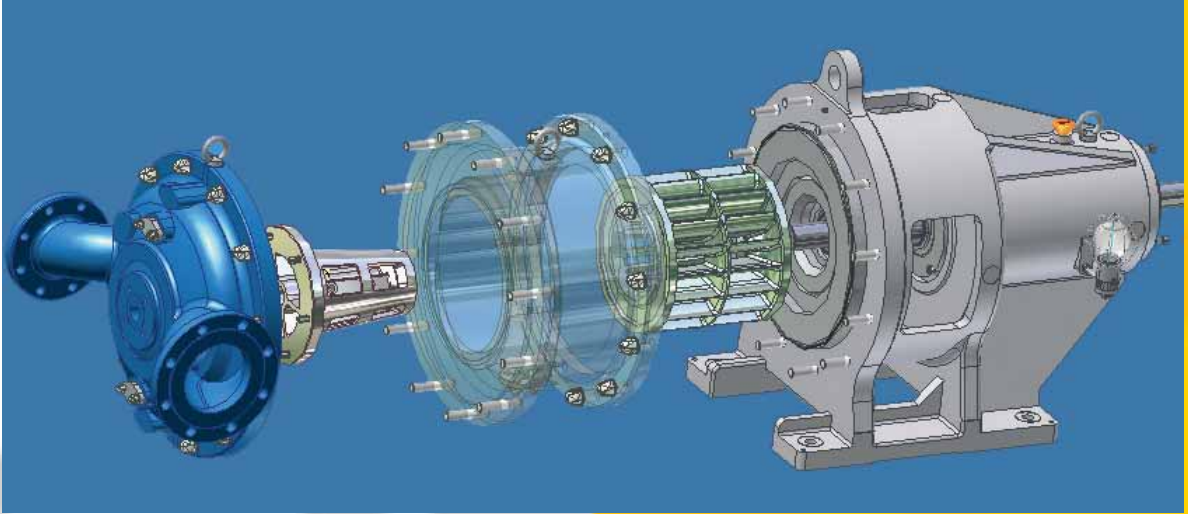

Fast and Easy maintenance

## Specific features of Garo Liquid Ring Compressors

1. Rotor assembly axially displaceable.
2. Oil lubricated ball bearings.
3. Bearing-frame in carbon steel.
4. Replaceable casing.
5. shaft sleeve up to the bearing-frame.
6. shaft in AISI 630.
7. fully shrouded overhung impeller in one piece also for double stage.
8. One sealing point only.
9. single or double mechanical seal.
10. Four gaskets only.
11. Quick take-down front cover.

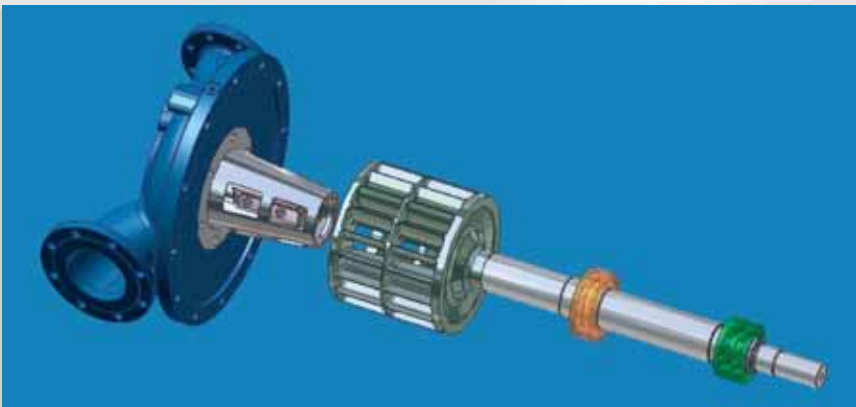
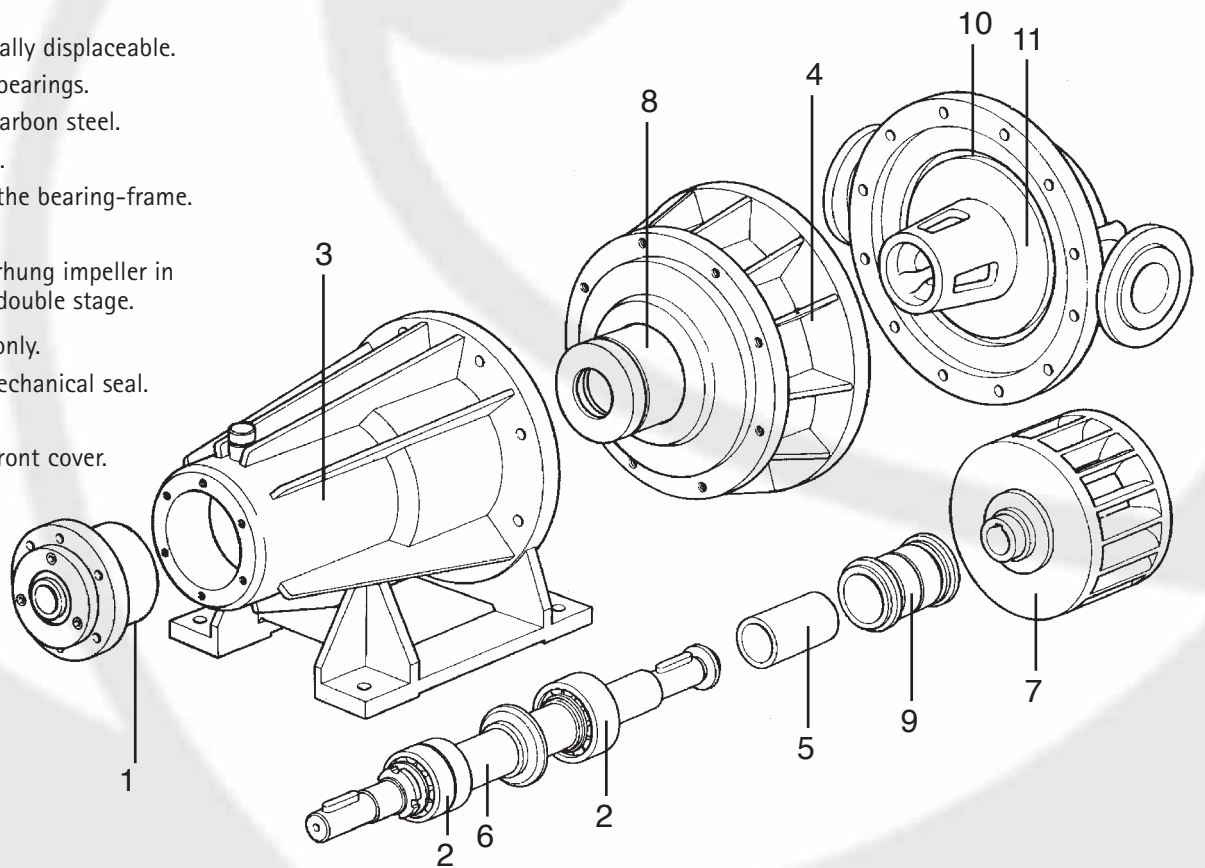

Overhung Impeller



Double lobe casing

# Performance Range



Garó **AM** Compressors Curves (50 Hz Area)

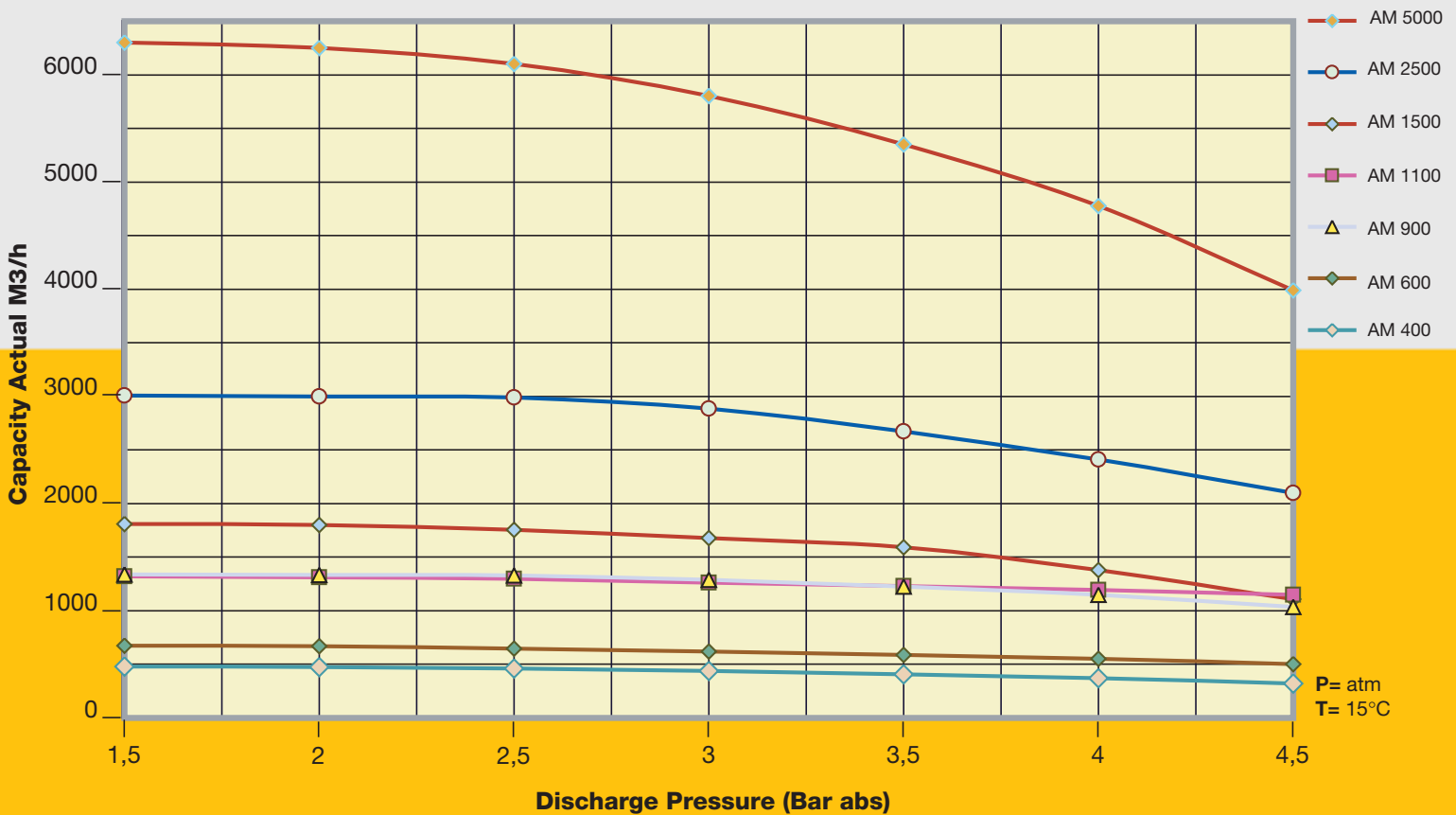

**Garo AB Compressors Curves (50 Hz Area)**

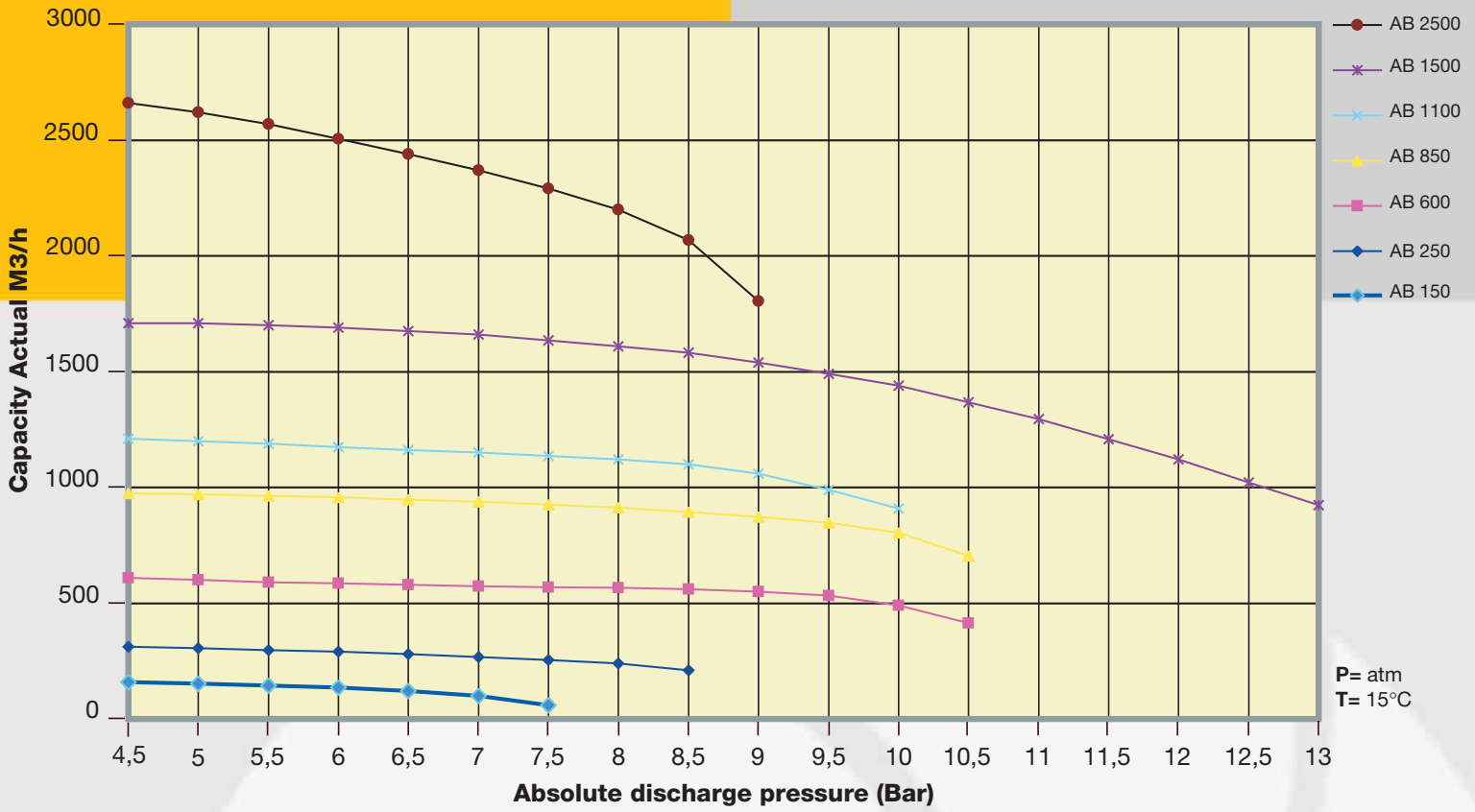

Garo



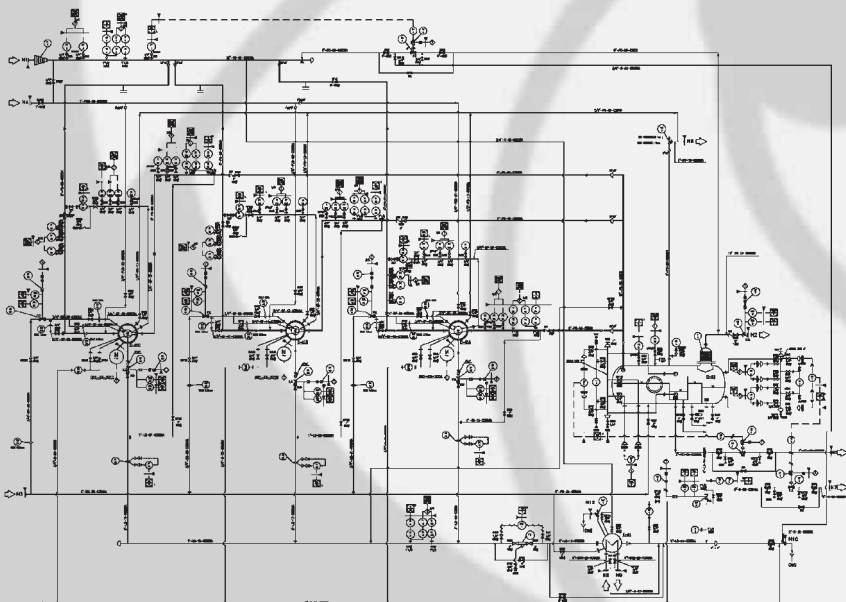

■ Flare gas recovery unit during assembling phase in the shop

■ P&I Drawing





Garro Dott. Ing. Roberto Gabbioneta S.p.A.

20052 MONZA - Via Pompei, 15 - Italy  
Tel. 039.839601 - Fax 039.835720  
info@garro.it - www.garro.it